

LAD **LIGHT DAVIT CRANE**

EN 795/B

Notified body which supervises the production of the equipment
(*Notified body which supervises the production of the equipment*):

**APAVE SUDEUROPE SAS - BP 193 - 13322 MARSEILLE CEDEX
16 - FRANCE**

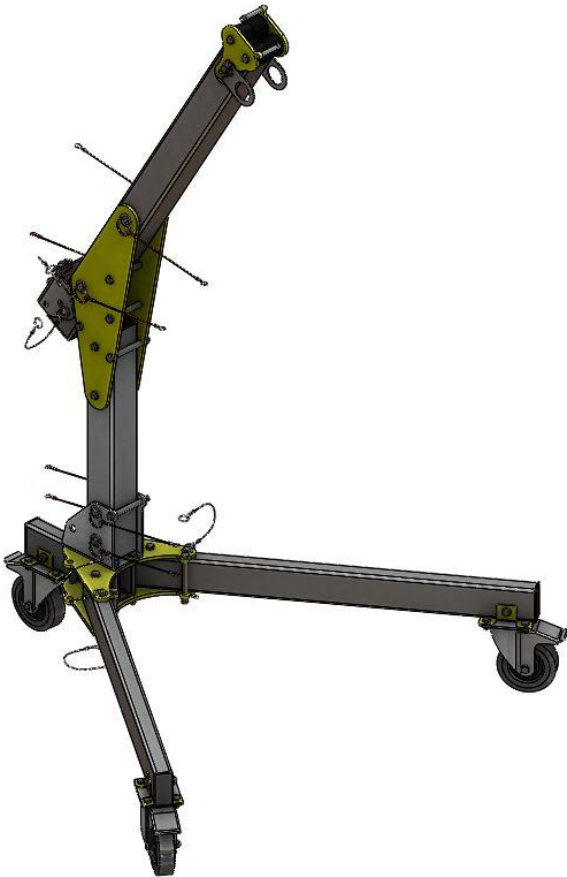

Figure 1 – Overview

TABLE OF CONTENTS:

1.	GENERAL DESCRIPTION	2
2.	LOAD LIMIT AND STRENGTH.....	3
3.	TRANSPORT AND WEIGHT.....	4
4.	MAINTENANCE AND STORAGE.....	4
5.	GENERAL DIMENSIONS	5
6.	TIME OF USAGE.....	5
7.	PERIODIC INSPECTIONS	5
8.	MARKING OF DEVICE.....	5
9.	INSTALLATION OF DEVICE	6
10.	INSTALLATION OF RESCUE DEVICES.....	8
11.	INSTALLATION OF DEVICE CRW200/CRW300	8
12.	ESSENTIAL PRINCIPLES FOR USE OF PERSONAL FALL PROTECTION EQUIPMENT	8
13.	WARRANTY	9
14.	IDENTITY CARD	10

1. GENERAL DESCRIPTION

Aluminium davit crane LAD is an anchor point compliant with EN795/B. It is designed for protection of maximum 1 user at a time. The device is made of strengthened, anodised or powder-coated aluminium, and stainless-steel elements.

The device can be folded easily for transport or disassembled into three separate modules, the weight of which is no greater than 25kg (individual modules are connected using pins with cotters):

- a) Bracket with foldable legs and socket for vertical post. The bracket is equipped with 3 wheels with a diameter of 160mm each, in swivel casings, with brake, allowing for movement of the crane in the work area.
- b) Vertical post with socket for mounting of jib.
- c) Jib with pulley, anchor point and socket for installation of rescue lifting device.

Additional components (sold separately):

Personal fall protection equipment (retractable type fall arresters, lines, etc.) can be mounted to the device LAD using swivel eye found at the end of jib.

Rescue lifting devices RUP502-U, RUP504, RUP506 can be mounted to the device LAD using a universal holder for rescue lifting devices PAD100-301-000. Device CRW200 can be installed using additional holder PAD100-310. Device CRW300 can be installed using additional holder PAD100-320.

Universal holder for rescue lifting devices, made of galvanized steel PAD100-301-000 (weight ~2kg) can be installed at the end of jib: Work rope is then guided through the pulley with rollers installed at the end of jib.

Rescue lifting devices RUP502-U, RUP504-U, RUP506-U can be mounted directly to the device PAD using a universal holder for rescue lifting devices PAD100-301-000.

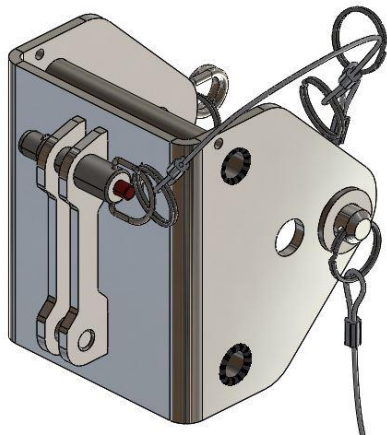

Figure 2 – Universal holder for rescue lifting devices PAD100-301-000.

Device CRW200 can be installed using additional holder PAD100-310.



Figure 3 – Holder PAD100-310 for device CRW200.

Device CRW300 can be installed using additional holder PAD100-320.

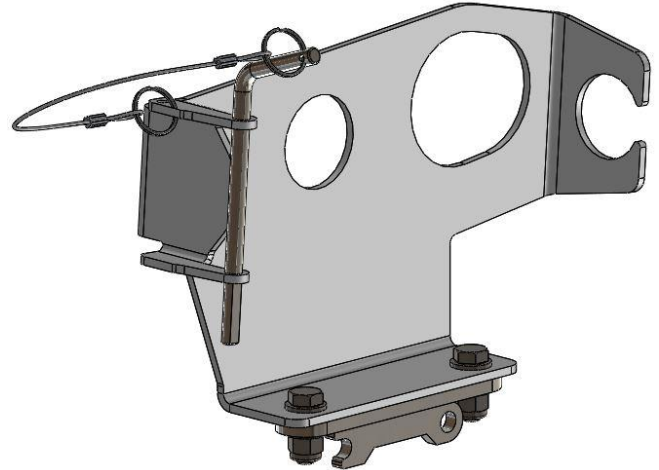

Figure 4 – Holder PAD100-320 for device CRW300.

Universal holder for rescue lifting devices, made of galvanized steel PAD100-301-000 (weight ~2kg) can be installed at the end of jib:

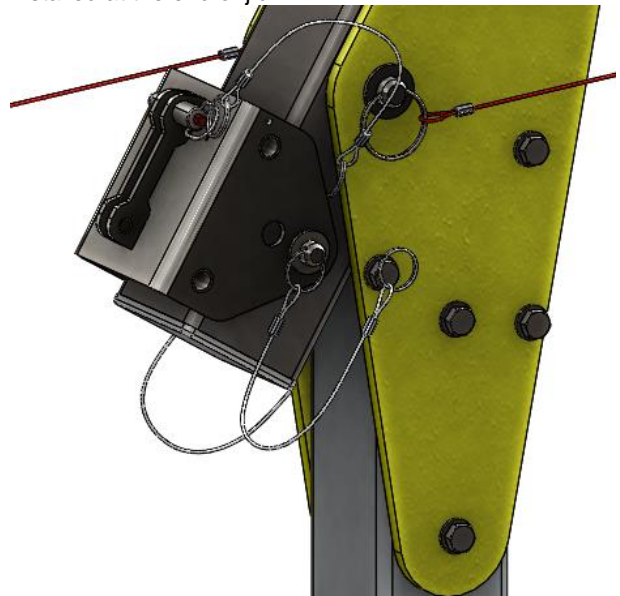

Figure 5 – Universal holder for rescue lifting devices PAD100-301-000 installed at the end of jib.

Work rope is then guided through the pulley with rollers installed at the end of jib.

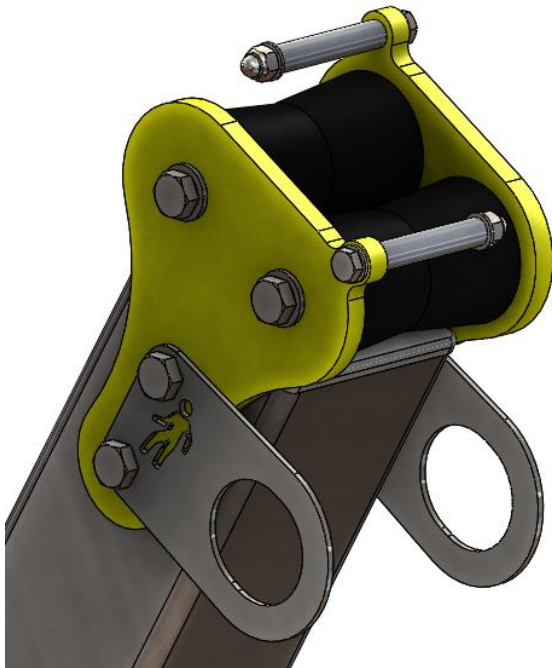

Figure 6 – Guidance of work rope of device installed on jib through pulley.

2. LOAD LIMIT AND STRENGTH

a) GENERAL INFORMATION

Minimum Breaking Strength (MBS): 12kN.

The device can be loaded vertically downwards within a space limited by legs of the device.

The maximum load that could be transmitted in service from the device to the static construction – 10 kN (***The maximum load that could be transmitted in service from the device to the static construction.***)

If the device is used as a part of a fall arrest system, the user must be equipped with an element limiting maximum dynamic forces applied on user while arresting a fall to max. 6kN.

b) FOR MATERIAL TRIPODS

installed on the jib using universal holder PAD100-301-000:

Working Load Limit (WLL): 500kg
Safety Factor (SF): 2,4:1.

c) FOR PERSONAL PROTECTIVE EQUIPMENT (PPE) mounted to anchor points located at the end of jib:

Maximum 1 user at the same time. Whereas one user is connected to one anchor point.

According to the requirements of EN 795/B strength of the device is min. 13kN

d) FOR PERSONNEL RESCUE DEVICES installed on tripod leg with use of universal holder PAD100-301-000:

Working Load Limit (WLL): 120kg

Safety Factor (SF): 10:1.

Work load of rescue device used cannot be greater than 120kg.

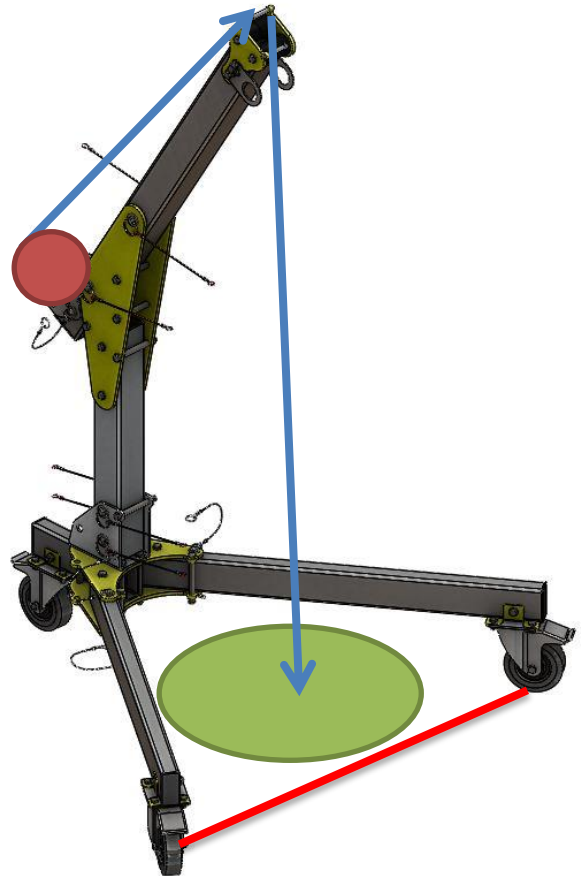

Figure 7 – Permissible directions of loading of anchor point within inner area determined by tripod legs

3. TRANSPORT AND WEIGHT

Weight of complete device: 35.72kg.

Personal fall protection equipment must be transported in a package (e.g.: bag made of moisture-proof textile or foil bag or cases made of steel or plastic) to protect it against damage or moisture.

4. MAINTENANCE AND STORAGE

Personal protective equipment should be cleaned without causing adverse effect on the materials used in the manufacture of the equipment. For textile materials (webbings, ropes) use agents suitable for delicate fabrics. Can be washed in hands or in a washing machine. Rinse thoroughly. Wash textile elements with water only. - When the equipment becomes wet, either from being in use or after cleaning, allow it to dry naturally, and keep it away from sources of heat. In metallic products lubricate slightly some mechanical parts (springs, hinges, pawls, etc.) regularly to ensure their better operation.

Personal fall protection equipment should be stored loosely packed in well-ventilated rooms, protected from direct light, UV degradation, dust, sharp edges, extreme temperatures and aggressive chemical substances.

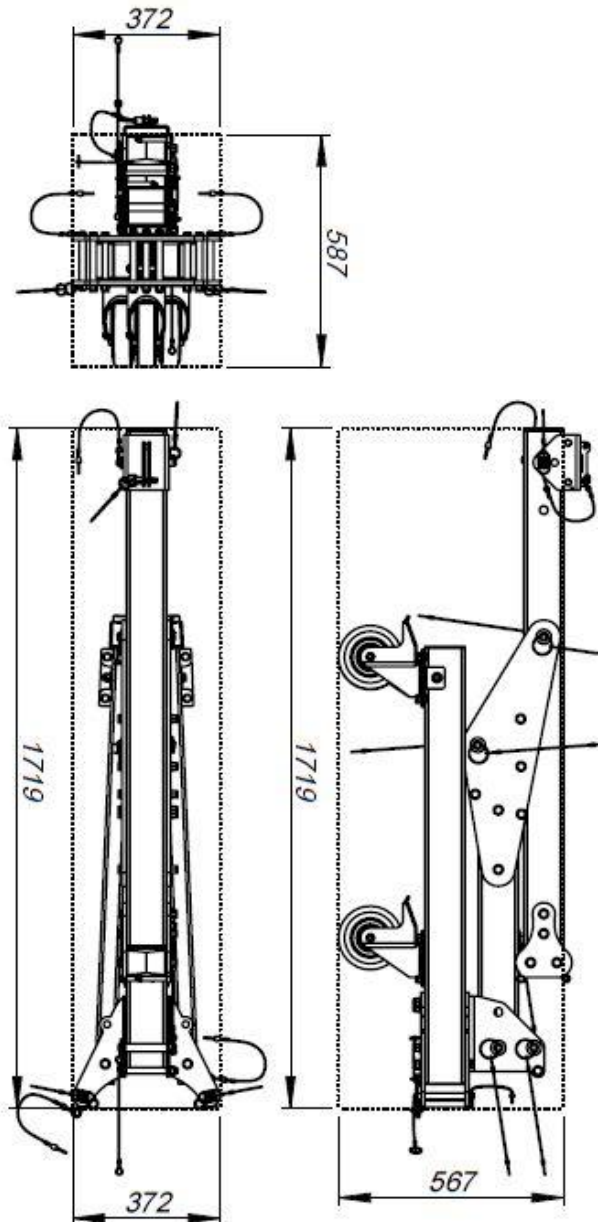

Figure 8 – Transport dimensions

5. GENERAL DIMENSIONS

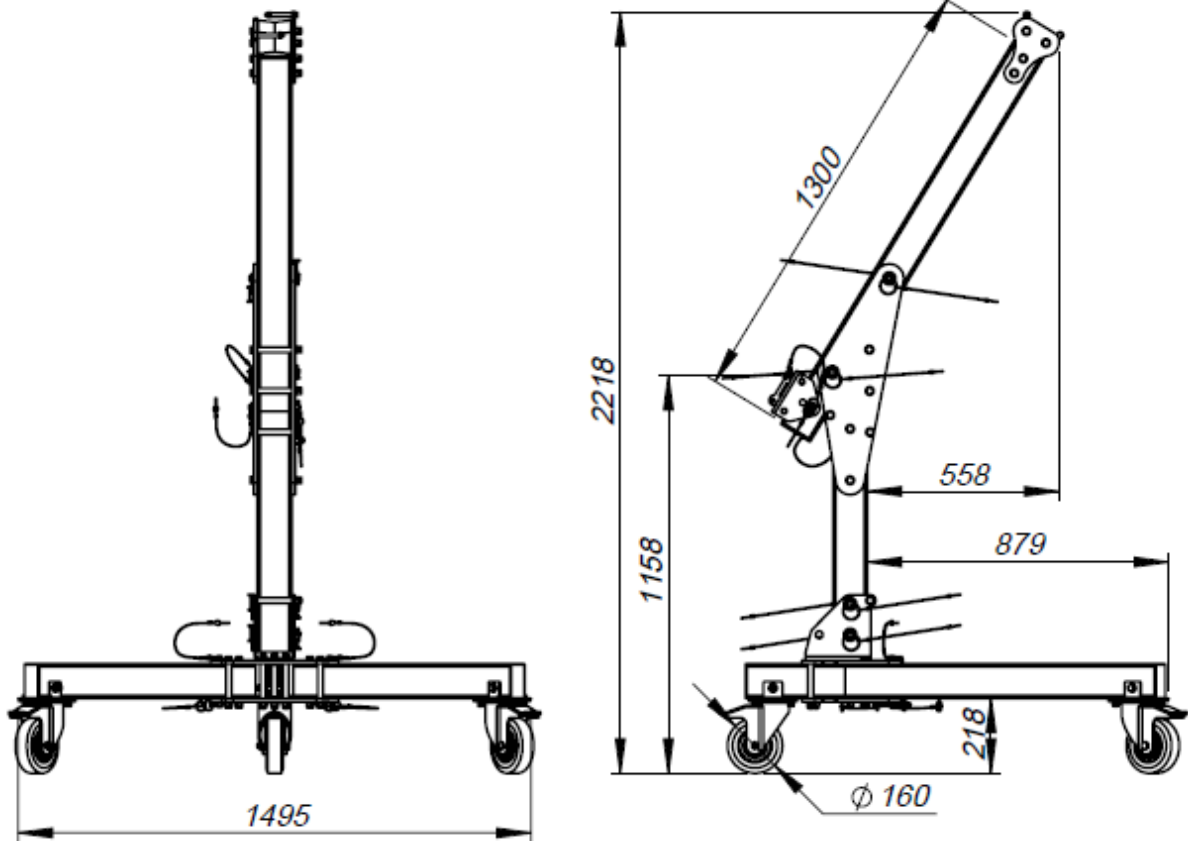

Figure 9 – General dimensions of device – front view

6. TIME OF USAGE

Maximum time of usage of correctly operating devices is unlimited.

The device must be withdrawn from use immediately and destroyed if it has been used to arrest a fall or there are any doubts concerning its function.

NOTE: Maximum time of usage of the device depends on intensity and environment of use. If the device is used in heavy conditions, being exposed to frequent contact with water, sharp edges, corrosive substances, extreme of temperatures, it may be necessary to withdraw the device after only one use.

7. PERIODIC INSPECTIONS

At least once a year, after every 12 months of use, it is necessary to carry out periodic detailed inspection of the device.

Periodic inspection may be carried out by a properly qualified and skilled person.

After 5 years of use, it is recommended that periodic inspections are carried out by the manufacturer of the equipment or an entity authorised by the manufacturer to carry out such inspections.

8. MARKING OF DEVICE

Marking:

- Name/ type of device
- Device model designation.
- Reference number.
- Number/year/class of European standard.
- CE mark and number of notified body which supervises the production of the equipment.
- Month and year of manufacture.
- Serial number of device.
- Attention: read instruction manual.
- Mark of manufacturer or distributor of device.
- Maximum number of concurrent users



Figure 10 – Identity label of device

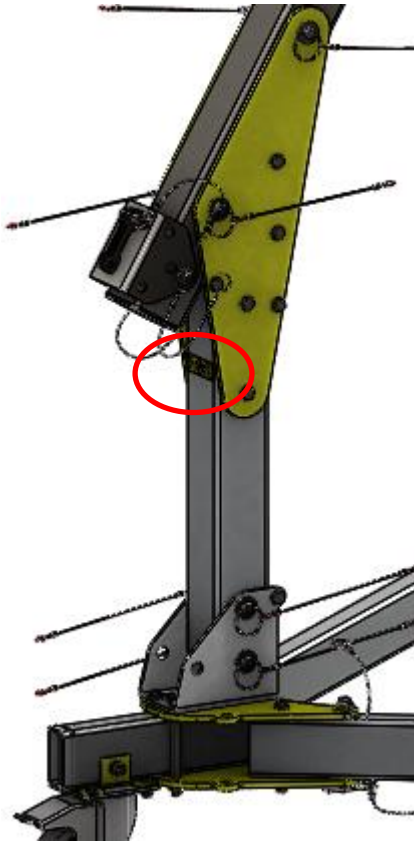

Figure 11 – Location of markings



Figure 12 – “Next inspection” sticker

“Next inspection” sticker should be affixed near identity label and it is necessary to mark month and year of the next periodic inspection. Do not use the device after this date.

Note: Before the first use, mark the date of next inspection (date of first use + 12 months, e.g. first use 01.2013 – mark 01.2014). “Next inspection” sticker affixed near identity label.

9. INSTALLATION OF DEVICE

The device can be deployed by one person. Place the device on a flat, stable and solid surface. Make sure that the surface can withstand load of the device.

- a) Device in folded (transport) position

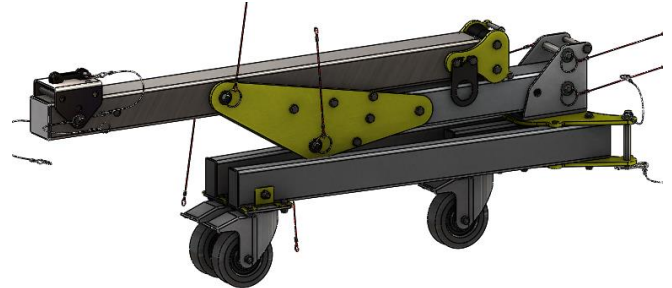

- b) Unlock two pins by removing the cotter and fully open both legs. Secure the legs again using pins with cotter.

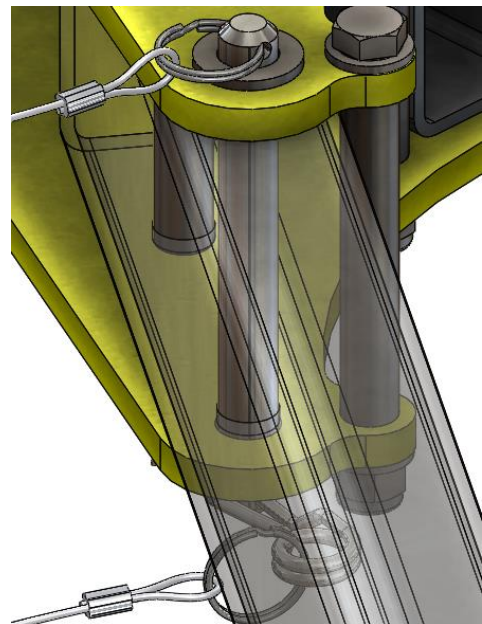

- c) Lift vertical post together with the jib and lock it in open position using pin with cotter.

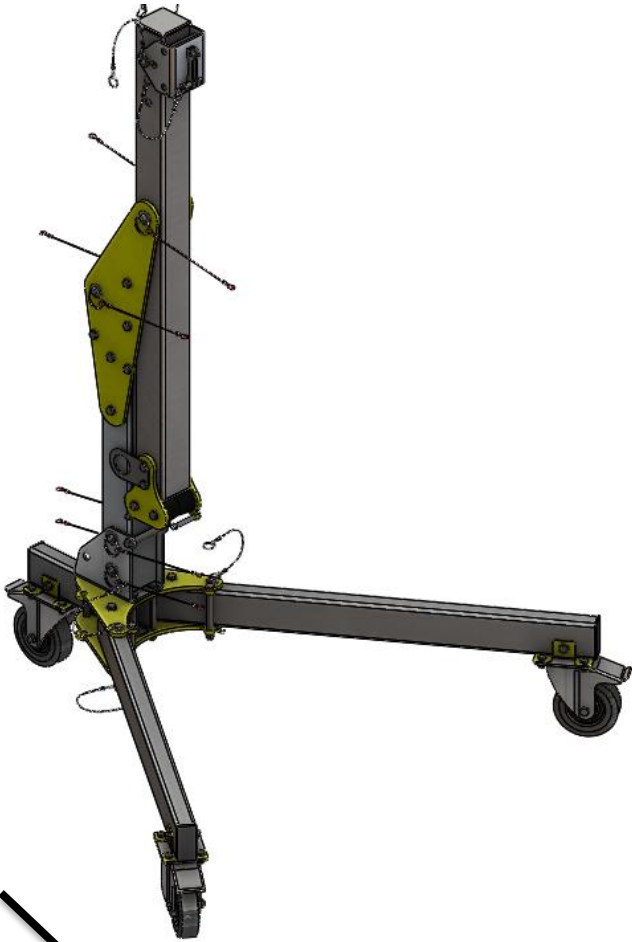

- d) Lift the jib and lock it in open position using pin with cotter.

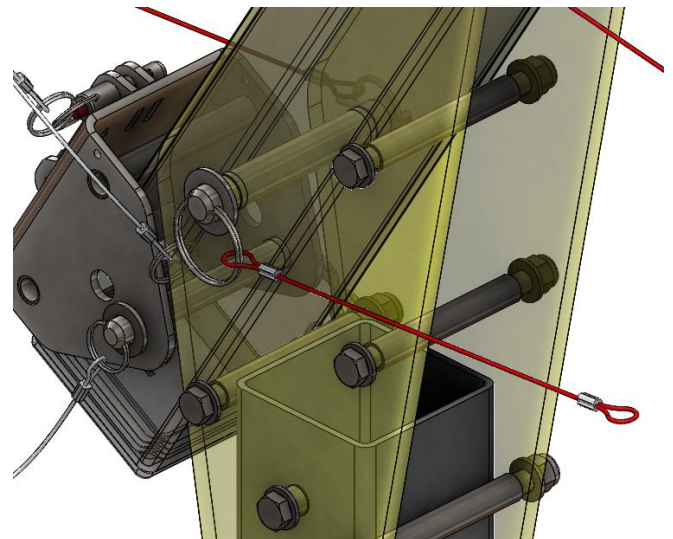
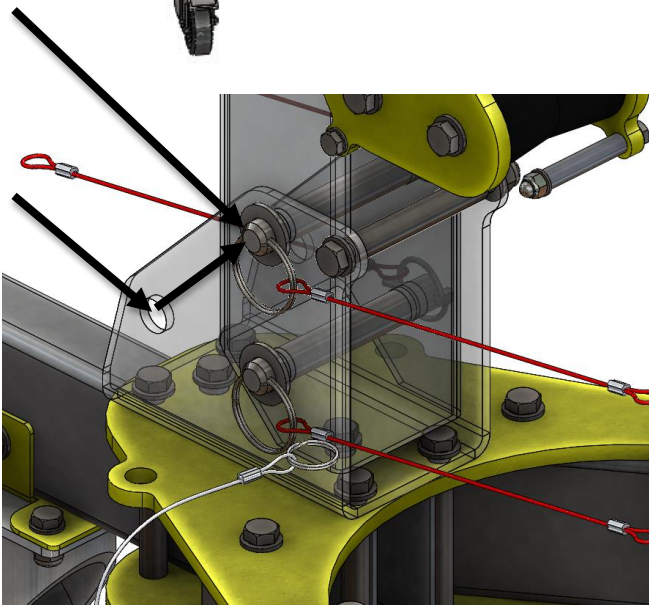
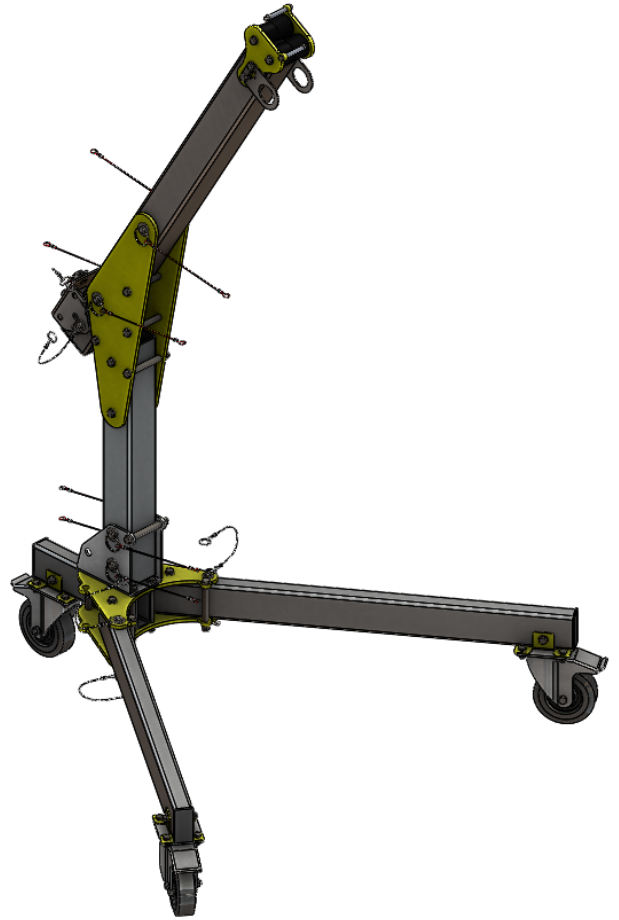

10. INSTALLATION OF RESCUE DEVICES

Rescue devices should be installed on the device LAD using universal holder for rescue lifting devices PAD100-301-000 as presented below (secure the connection using special pin).



11. INSTALLATION OF DEVICE CRW200/CRW300

Devices CRW200/CRW300 should be installed on holder for PAD100-301-000 using intermediate clip.

- a) PAD100-310 for CRW200
- b) PAD100-320 for CRW300



12. ESSENTIAL PRINCIPLES FOR USE OF PERSONAL FALL PROTECTION EQUIPMENT

- The device LAD must be used in accordance with instruction manuals for personal fall protection equipment and standards:
 - EN 361 - for full body harnesses
 - EN 352-3; EN 355; EN 360 - for fall restraint devices
 - EN 362 - for connectors
 - EN 795 / TS16415 - for anchor points
- personal fall protection equipment should be used only by personnel trained in its use.
- personal fall protection equipment must not be used by a person with medical condition that could affect the safety of the equipment user in normal and emergency use.
- prepare a rescue plan to be implemented whenever necessary.
- it is forbidden to make any alterations or additions to the equipment without prior written consent given by the manufacturer.
- any repair shall only be carried out by manufacturer of the equipment or his certified representative.
- personal fall protection equipment shall not be used for any purpose other than intended.
- personal fall protection equipment provides individual protection and shall be used by one person only.
- before each use make sure that all parts of fall protection system cooperate correctly. Periodically examine connections and fitting of components of the equipment to prevent any accidental loosening or disconnection.
- it is forbidden to use a combination of the equipment where function of any one item is affected by, or interferes with the function of any other.
- before each use of personal fall protection equipment, a pre-use check should be carried out to ensure that it is in a serviceable condition and operates correctly.
- In particular, inspect all accessible elements of the equipment for any damages, excessive wear, corrosion, abrasion, cutting or improper function. For individual devices pay particular attention to:
 - ✓ in full body harnesses and work positioning devices: buckles, regulating elements, attachment points (buckles), webbing, seams, belt loops;
 - ✓ in energy absorbers: attachment loops, webbing, seams, housing, connectors;
 - ✓ in lanyards and textile guides: rope, loops, thimbles, connectors, regulating parts, splices;
 - ✓ in lanyards and steel guides: rope, wires, clamps, loops, thimbles, connectors, regulating parts;
 - ✓ in retractable type fall arresters: lanyard or webbing, retractor and locking mechanism for proper operation, housing, energy absorber, connectors;
 - ✓ in guided type fall arresters: body, proper guiding, locking mechanism for proper operation, rollers, bolts and rivets, connectors, energy absorber;
 - ✓ in connectors (snap hooks): load-bearing body, rivets, main pawl, locking mechanism functionality.

- at least once a year, after each 12 months of use, personal fall protection equipment must be withdrawn from use to carry out periodic detailed inspection. Periodic inspection may be carried out by a person who is responsible for periodic inspections in user's organisation and properly trained in this respect. Periodic inspections can be carried out also by manufacturer of the equipment or his authorized representative, or an authorized company. Inspect in detail all accessible elements of the equipment paying attention to any damages, excessive wear, corrosion, abrasion, cutting or incorrect function (see the above item.) In some cases, if fall protection equipment has a complex design (e.g. fall arresters), periodic inspections can be carried out by manufacturer of the equipment, or his authorized representative only. After the periodic inspection, date of the next inspection should be defined.
- Regular periodic inspections are essential in respect of the equipment condition and safety of users which is dependant on functionality and durability of the equipment.
- during periodic inspection it is necessary to check the legibility of all markings on the equipment (identity label of the device).
- all information on fall protection equipment (name, serial no., date of purchase and date of first use, name of user, information on repairs and inspections and withdrawal from use) must be provided in the Identity card of the device. It is responsibility of user's organisation to provide the Identity card and to fill in the required details. The Identity card should be filled in by a person in charge of fall protection equipment in user's organisation. It is forbidden to use personal fall protection equipment if the Identity card is completed.
- if the equipment is re-sold outside the original country of destination the reseller must provide instructions for use, for maintenance, for periodic inspection and for repair in language of the country where the product is to be used.
- Personal fall protection equipment must be withdrawn from use immediately if any doubts arise in regard of its condition, or proper operation. The equipment must not be used until manufacturer of the equipment carries out a detailed inspection and gives his written consent to use the equipment again.
- Personal fall protection equipment must be withdrawn from use immediately and destroyed if it has been used to arrest a fall.
- full body harness is the only admissible device to be used to support the user's body in personal fall protection equipment.
- in full body harness use only attaching points (buckles, loops) marked with capital letter "A" to attach a fall protection system.

13. WARRANTY

The manufacturer grants a warranty for 12 months from the date of purchase of the device. If a defect is found in any part, the warranty and guarantee period for this part is extended by the time of repairs and effective removal of the defect found.

The warranty covers:

- Defects in material,
- Structural defects,
- Anti-corrosion coating defects

According to the requirements of EN 365 an anchor point shall be subject to periodic inspections carried out at least every 12 months. Periodic inspection shall be carried out by the manufacturer's authorized service point located at the following address:

**PROTEKT Grzegorz Łaszkiwicz
ul. Starorudzka 9**

93-403 Łódź

or person trained in inspections of such equipment.

A trained person is a person who, based on own specialized education and adequate experience, has sufficient knowledge in installed protective and rescue equipment, and is familiarized with applicable OHS regulations, guidelines and generally acknowledged technical rules to such extent that is able to assess safety of use and correct application of protection devices.

Before each use of the system check whether date of the next inspection is not expired. Do not use the device after this date. Before each use of the system visually check the system for its integrity and technical condition and whether steel cable is tensioned.

If any defect or lack of integrity is found, do not use the point.

If any doubts arise as for the use of the equipment, please contact the manufacturer and never repair the equipment on your own!

A system which has been used to arrest a fall must be withdrawn from use immediately!

The system which has been used to arrest a fall may be admitted for use again after a detailed inspection is carried out by the manufacturer or an authorised service point.

When using the system, pay special attention to risks affecting the protective equipment operation or the user's safety, and in particular to kinks and rope movement on sharp edges, oscillatory falls, electricity, influence of extreme temperatures, equipment damage, adverse environmental factors, chemical substances and contamination.

Neither modify, repair components of the system nor replace them with non-original spare parts.

14. IDENTITY CARD

IDENTITY CARD – LAD..... (in accordance with EN365)					
Reference number of device	LAD000-000-000		Serial number:	
Date of first use (installation)		Date of manufacture:	
Installation location				
User name:				
Inspection and repair record					
No .	Date of inspection	Type of inspection / repair	Remarks	Date of next inspection	Name and signature of service technician
1					
2					
3					
4					
5					
6					
7					
8					
9					
10					